

Integrated Dc Electric Refrigeration Unit — B-100/B-100C

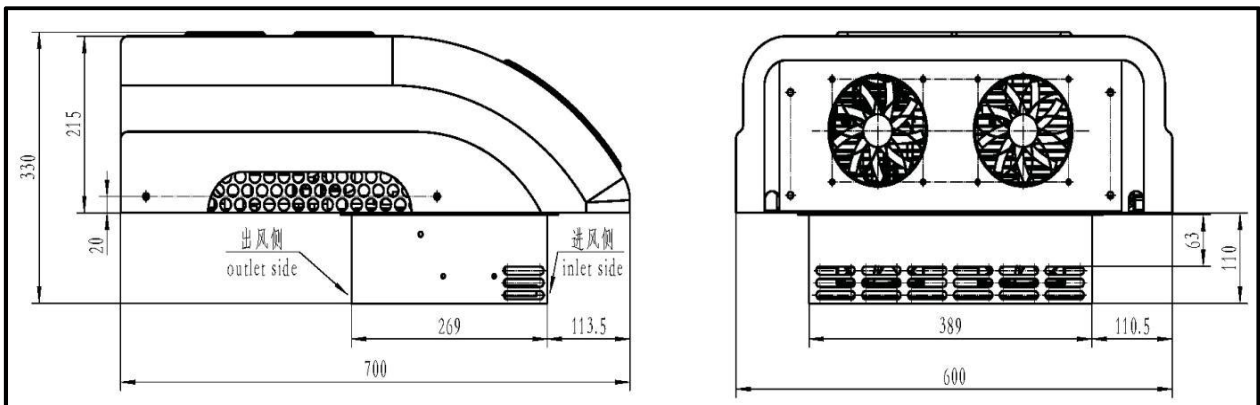

- Full electric refrigeration units,DC12V-DC72V are optional
- Quick Installation, simple maintenance and low maintenance cost
- Full digital control, easy to operate
- DC powered driven (12V/24V/48V/72V/96V etc.)
- Green and Environmental Protection.

Model	B-100C	B-100
Structural Pattern	Integrated unit	
Cooling capacity	600~1000W (0℃)	500~1000W (-18℃)
Power Consumption	300~500W	300~800W
Volume of container (m ³)	≤ 2 (0℃)	≤ 1.5 (-18℃)
Condenser	Parallel flow	Parallel flow
Evaporator	copper pipe	copper pipe
Compressor	YQ25D48 (25cc/r)	YQ25D48 (25cc/r)
Compressor Voltage	DC48V/60V	DC48V/60V
Refrigerant	R134a 0.5~0.6 Kg	R404a 0.5~0.6 Kg
Dimension (mm)	700×600×215 (not include evaporator)	700×600×215 (not include evaporator))
Numbers of fans and air volume	evaporator	2/600m ³ /h
	condenser	2/600m ³ /h